

SERIE

SPIDER 30 T

SELF-PROPELLED AERIAL WORK PLATFORMS

PROVISIONAL

COMPTOIR DU LEVAGE

Vente, location de matériel avec ou sans opérateur et gestion de projet

comptoirdulevage.fr

07 68 55 39 82 contact@comptoirdulevage.fr

SIRET : 850 301 227 00011

NOVITA' NEWS



Lightweight, agile and extremely compact at 30m of working height.

- Only 88cm (35 inches) wide to go throughout a single door.

- Automatic stabilization & automatic storage device

- Fast to be operated in multifunctions.

SIMPLIFIED MAINTENANCE

- Easy access to any maintenance compartment.

- On-board diagnostics

- Tele assistance on demand

PLATFORM

B A S K E T

SERIE SPIDER 30 T

BEST PERFORMANCES

1. Stiff tele-boom with multi-sections and flying jib

- Fast tele-boom movement to go in & out
- Easy operations with flying jib at the tip of the tele-boom.
- Unrestricted 27m working height



2. Enjoy the experience of easy controls

- Proportional, smooth and precise movements.
- Automatic & proportional side outreach that allows the users to enjoy the sensation of stability, reliability and full control of the spider
- Radio remote control, with a selector fast/slow for the drive, automatic recovery button, standard automatic stabilization and self-diagnostic. The system is supplied with a spare cable



3. Attention to the details

- Compact design & highest quality components – strong & reliable
- Air & Water & 220/110 Vac outlets into the basket.
- Cranked outrigger design for increased ground clearance
- Fully protected by metal shields.



4. Multi-width stabilizers setting.

- Asymmetric stability system to enable a free positioning of the legs independently and monitoring the side outreach.
- Automatic locking device to make the positioning of the legs easy

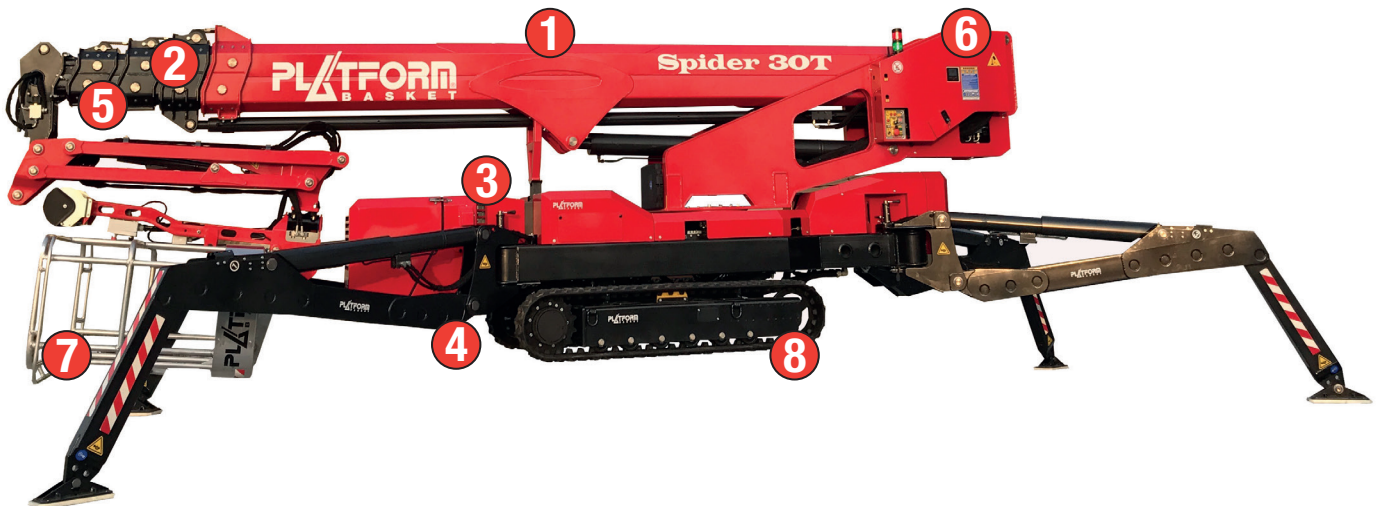

5. Automatic & Proportional Outreach side Control

- The safety system automatically reduce the outreach by monitoring always the weight into the basket.
- The automatic outreach allows to operate up to the maximum height with 230 kg lifting capacity.



6. Remote diagnostics and fleet management (Option)

- The remote diagnostics helps offering a range of unique benefits, including immediate communication of actionable information so you can make decisions in real-time.
- Proactive diagnostic and repair planning assistance with detailed analysis of critical fault codes, and update of the software.
- In addition the GPS locator allows you to know exactly where the spider is.



7. Quick detach and interchangeable cage

- Aluminium basket 1,8m wide, easily detachable.
- Basket rotation 90°+90° deg
- Electric system to check whether the basket is properly fitted, enabling the lifting movements. (new EU standards)

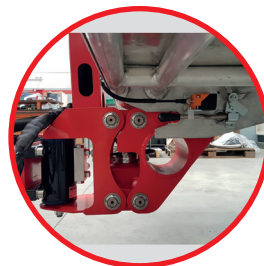

8. Hydraulic track widening system

- Wide tracks 1290 mm for extremely stability while driven.
- Excellent versatility on narrow doorway passages, with 880mm only when tracks are in narrow set-up.
- Two speed tracking up to 2,00 Km/h.
- two speed track ideal for better mobility when battery powered



OVERALL DIMENSIONS

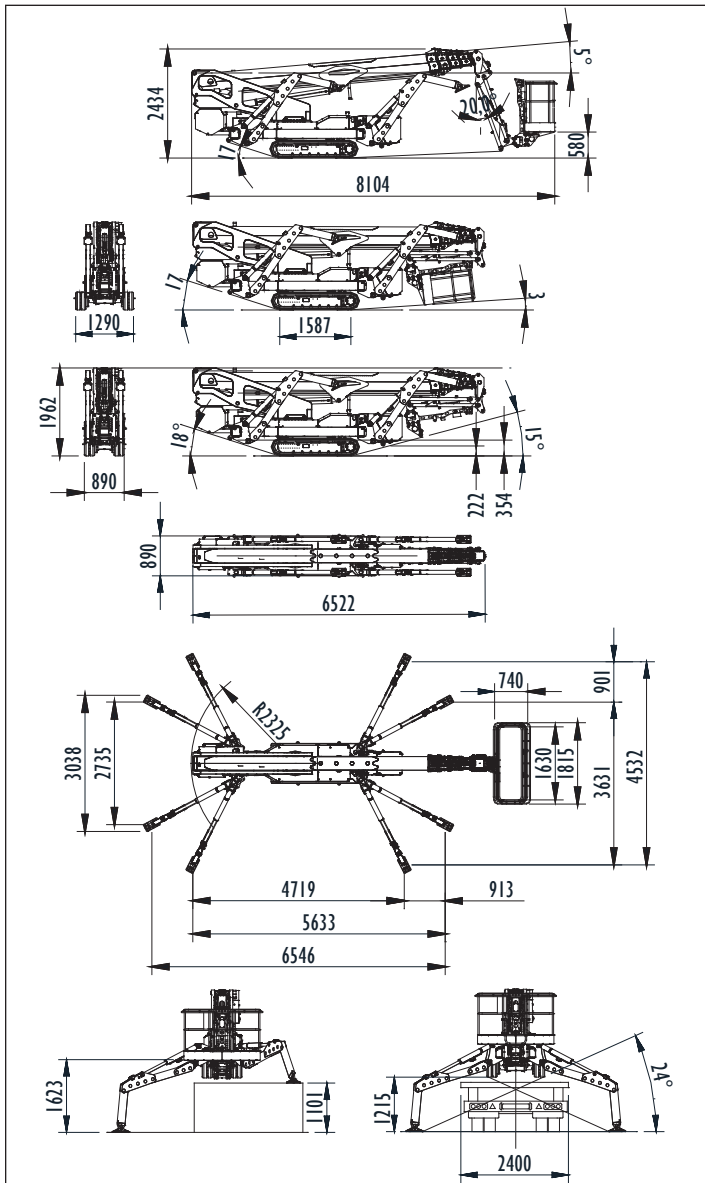

WORKING ENVELOPE

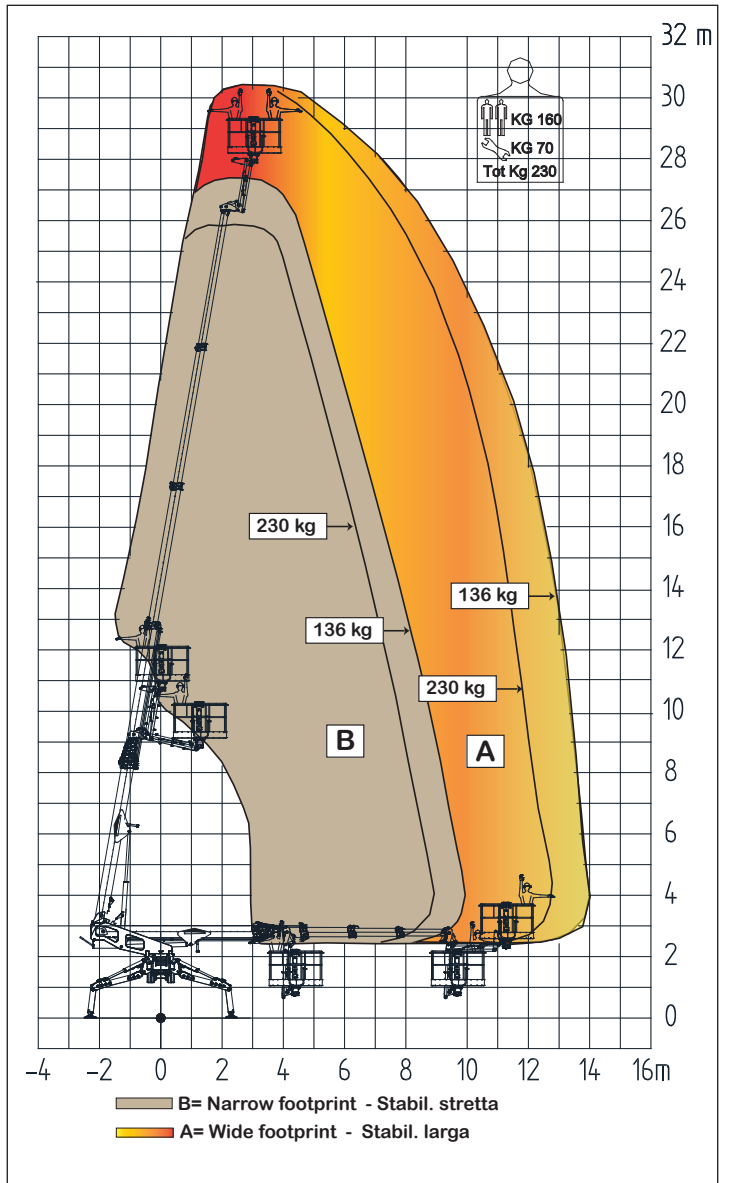

OPERATIONS

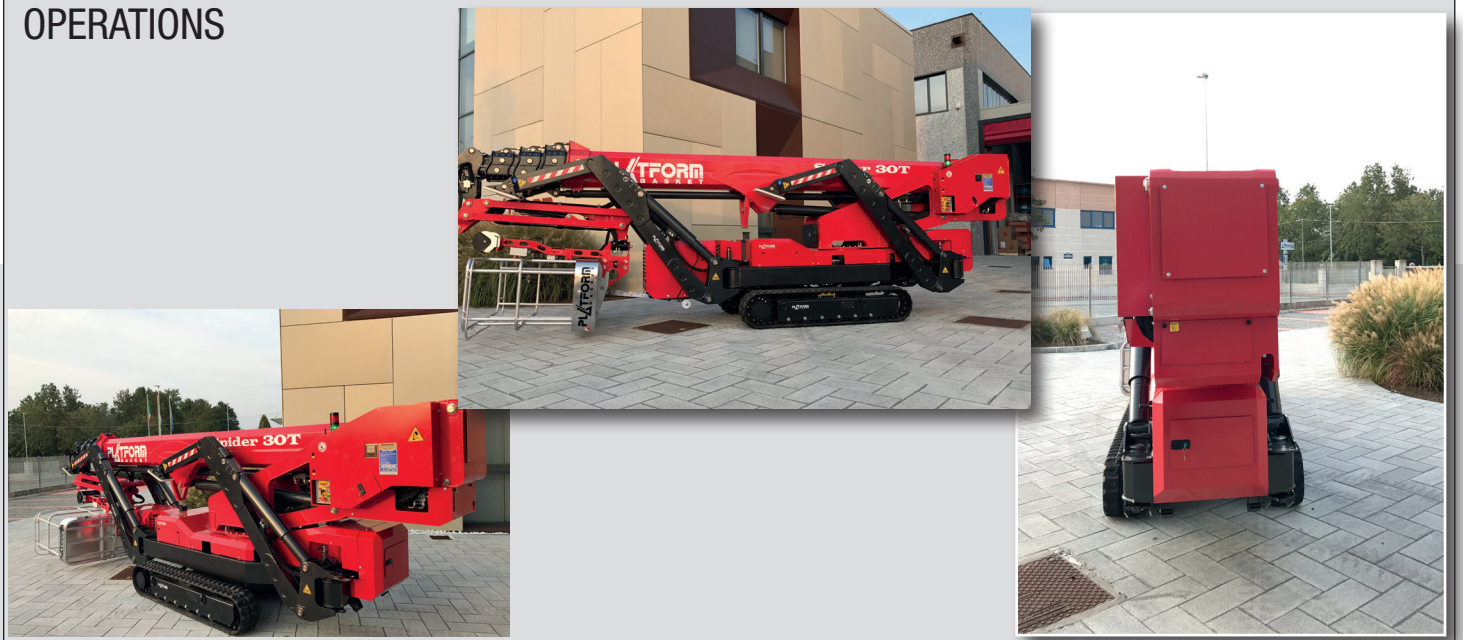

SERIE SPIDER 30 T

TECHNICAL DATA		VERSION	
		STD	ED
Max working height	m	30,3	
Max height basket floor	m	28,3	
Max side outreach	m	14,2	
Rotation angle	°	360	
Basket size (standard version)	m	1,80 X 0,80	
Basket rotation angle	°	86+86	
Max basket capacity (2 men)	Kg	230	
Length in stowed position	m	6,52	
Min width in stowed position	m	0,89	
Min height in stowed position	m	1,96	
Stabilization foot-print	m	wide	4,53 x 4,72
	m	narrow	2,73 x 6,55
Max gradeability	deg/%	17 (31%)	
Max side gradeability	deg/%	16 (29%)	
Max speed	Km/h	2,0	
WEIGHTS		STD	ED
Weight in working config.*	Kg	4250*	4500*
Ground pressure stowed machine (narrow tracking)	KN/m²	3,49	3,66
Ground pressure when on stabilizers.	KN/m²	1,93	2,02
Max point load per outrigger plate	KN	26,8*	28,1*
POWER		STD	ED
Engine D902 Kubota diesel	hp/rpm	22/3600	22/3600
Electric motor 230Vac	hp/Volt	3/230	-
Electric motor 24Vdc	hp/Volt	-	7,4/24
Battery capacity 24Vdc lithium-ion	Ah	-	400
Battery charger - Lithium-ion	Ah	-	100/50

* Some weights may differ due to the chosen options.



STANDARD EQUIPMENTS	VERSION	
	STD	ED
Multi sections tele-boom with flying jib	•	
Radio remote control for drive & stab with diagnostic (supplied with emergency wire)	•	
Hydraulically extending under carriage	•	
Double proportional drive speed (slow/fast)	•	
Triple stabilization set-up and automatic monitoring device with no rotation restrictions.	•	
Auto-stabilization by radio remote control.	•	
Automatic recovering push button on-board.	•	
Light alloy basket, easily detachable	•	
Spare radio remote control batteries (2 supplied with charger included)	•	
Protected against falling objects by strong metal covers.	•	
Pipes & cables fully protected inside the booms.	•	
Electric outlets available into the basket 230/110Vac	•	
Air or water outlets into the basket (high pressure)	•	
Diesel KUBOTA water cooled engine.	•	•
Electric-pump 230Vac/3Hp single phase for indoor use	•	-
Deep-cycle batteries 24Vdc/400Ah, electric power-pack for indoor use.	---	•
Battery charger 24Vdc with power selector.	---	•
Phase inverter and electronic alert device.	•	---
EXTRAS - ON DEMAND	STD	ED
Non-marking tracks for delicate surfaces	•	
Electric emergency descent kit 24Vdc	•	---
Wind gauge to monitor max wind speed	•	
Basket working light	•	
Remote diagnostics and fleet-management	•	
Arctic lubricants for low temperature usage	•	•
Over-sized nylon plates and recovering frame	•	
Alu detachable basket 1,80x0,80m wide	•	
Alu detachable basket 2,20x0,80m wide	•	
INTERCOM device from basket to ground.	•	
Lithium-ion battery pack for longer working cycle	---	•
APPROVALS		
Europe EN280		

STD

 + 

- Combustion engine
- Electric motor-pump single phase 230/110 Vac

ED - HYBRID

 + 

- Combustion engine
- Electric pump 24Vdc with deep cycle battery



COMPTOIR DU LEVAGE

Vente, location de matériel avec ou sans opérateur et gestion de projet

comptoirdulevage.fr

07 68 55 39 82 contact@comptoirdulevage.fr

SIRET : 850 301 227 00011